

## Cardioid array 450 - 470 MHz

### DESCRIPTION

- A linear array of two VHF dipole elements with phasing harness mounted on an aluminium boom.
- Careful attention to element phasing results in a "Cardioid" shaped radiation pattern with high F/B ratio compared to an equivalent sized Yagi antenna.
- Antennas of this type find use in PMR/Trunked Radio and Broadcast applications needing very high F/B performance.
- Produced to the highest quality standards, these robust antenna designs will insure reliable operation in harsh environmental conditions.
- Former Jaybeam brand product.

### SPECIFICATIONS

Electrical	
Frequency	450 - 470 MHz
Max. Input Power	150 W
Polarisation	Vertical
3 dB Beamwidth, E-Plane	75 °
3 dB Beamwidth, H-Plane	180 °
Impedance	50 Ω
Gain	2.8 dBd (5 dBi)
VSWR	< 1.5:1
Front-To-Back Ratio	> 20 dB
Antistatic Protection	All metal parts DC-grounded (Connector shows a DC-short)

Mechanical	
Connection(s)	N(f) on 3 m RG213/U cable
Materials	Boom, 32 mm dia. aluminium elements, 12.7 mm dia. aluminium balun, fully moulded enclosure
Dimensions	650 x 290 x 100 mm (L x H x D)
Wind Load	113 N (160km/h)
Weight	2.5 kg / 5.51 lb
Mounting Bracket	3202078/68 + 3201079/00 (Ordered Separately)
Alternate Mounting Bracket	0900912/00, 0302032/68, or 0300064/00 + U-Bolts to match mounting pipe diameter (Ordered Separately)

### ORDERING

Model	Product No.	Frequency
Cardioid array 450-470 MHz	7170460	450 - 470 MHz

Accessories		
Galvanised steel crossover bracket 32/50mm	0900912/00	
Pressed steel cross clamp 2" x 1-1/4" (JBL73)	0302032/68	
Cast aluminium cross clamp, circular	0300064/00	
M8 x 50mm (2") U-Bolts (1 Pair)	4884036/00	
M8 x 75mm (3") U-Bolts (1 Pair)	4884076/00	
Fixed norstel / coupler clamp (cross clamp)	3202078/68	
Increasing sleeve	3201079/00	



### RADIATION PATTERNS

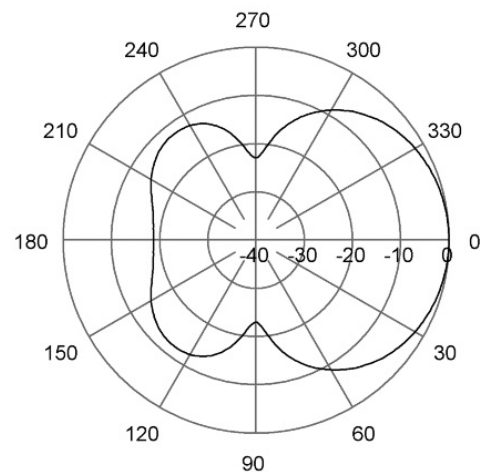

E-Plane | 460 MHz

### RADIATION PATTERNS

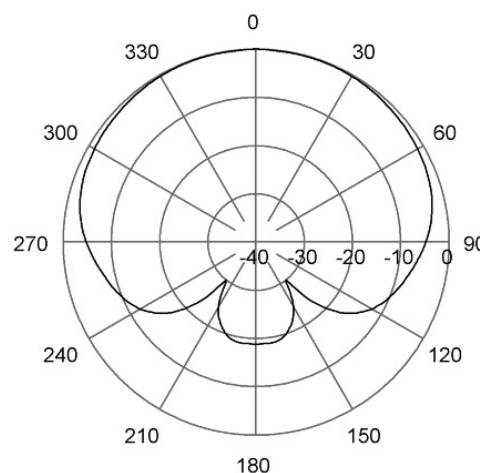

H-Plane | 460 MHz

